

MOTOR BUS TRANSFER

CONSIDERATIONS & METHODS

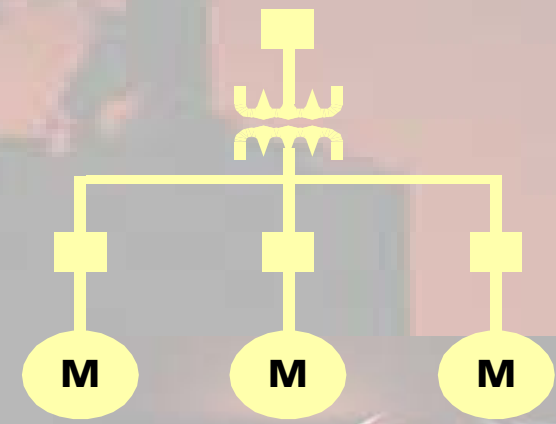

Introduction

- Definition of Motor Bus Transfer (MBT):
 - The process of disconnecting a motor bus from the present source of power and safely connecting it to an alternate source of power.

- A Bus Transfer can be:
 - Planned occurrence
 - Manual Transfer
 - Start-up / Shut down
 - Power supply security
(i.e. transfer to on-site source when storm approaches)
 - Maintenance
 - Unexpected (emergency) situation
 - Protection initiated
 - Fault or interruption on present supply
 - Breaker conflict

Introduction

- To maintain plant operation and process continuity, motor buses may require transfer from a present source to a new source
 - Power plants
 - Industrial plants with heavy loads
- Motor Bus Transfer (MBT) schemes and systems are employed to maintain process continuity in processes served by large motors or aggregates of smaller and large motors

Introduction

- The total mission of a MBT system is not only to maintain process continuity but also to affect source transfers so as not to cause any damage to the motors and connected loads.
- The coast down period and resultant voltage and frequency decay may take seconds, and unsupervised source transfer may cause damage.
- During improper transfer, mechanical damage may occur in the motor, the coupling to the load or the load itself, and is primarily caused by excessive shaft torque. This type of damage has a cumulative effect.

Unit-Connected Generator Motor Bus

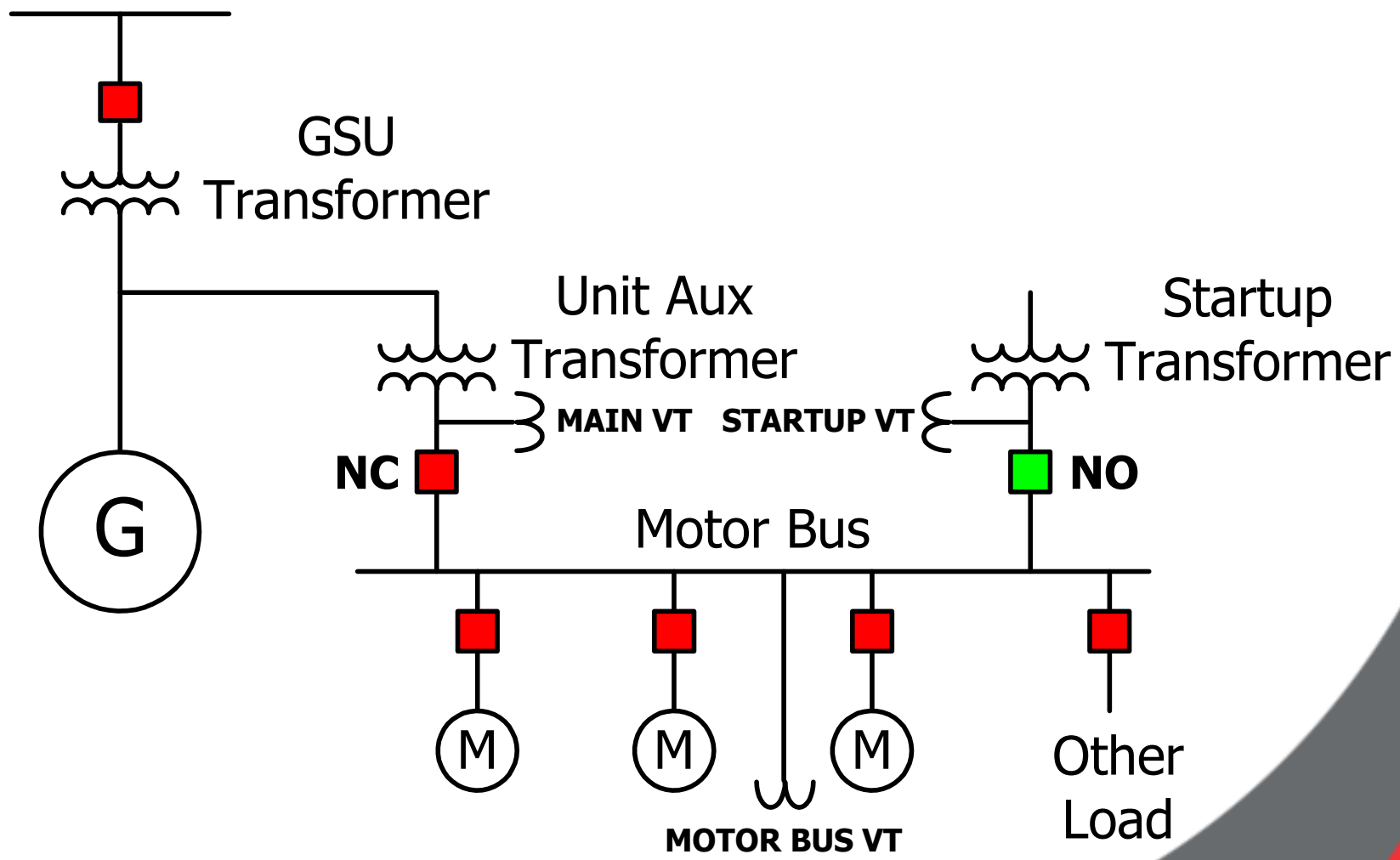

Typical Industrial Plant One-Line

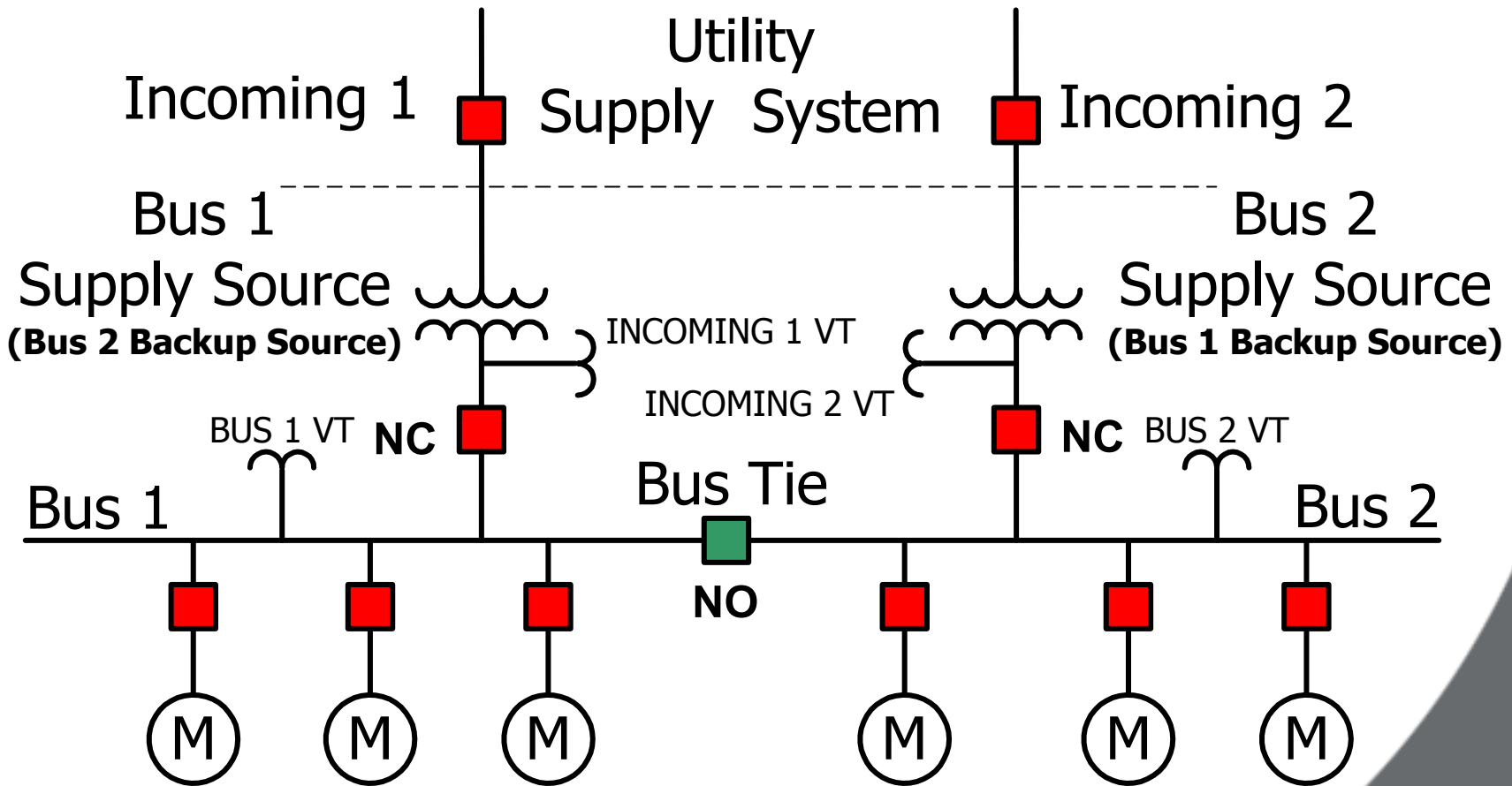

What are the Conditions across Normally Open Startup or Bus Tie Breaker?

- Under steady state and normal conditions the starting angle might or may not be 0°
- Immediately prior to Transfer Initiate
 - **Effects of a Fault** - System faults can cause the internal electrical angles of motors to differ from new source (i.e., single-phase faults)
 - **System Separation between Transmission or Distribution Incoming Supply Sources**
 - **Supply Source Transformer Winding Phase Shift**
- Immediately after Transfer Initiate, but prior to closure of Startup Source Breaker
 - **Transient Effects upon Disconnect of Motor Loads**

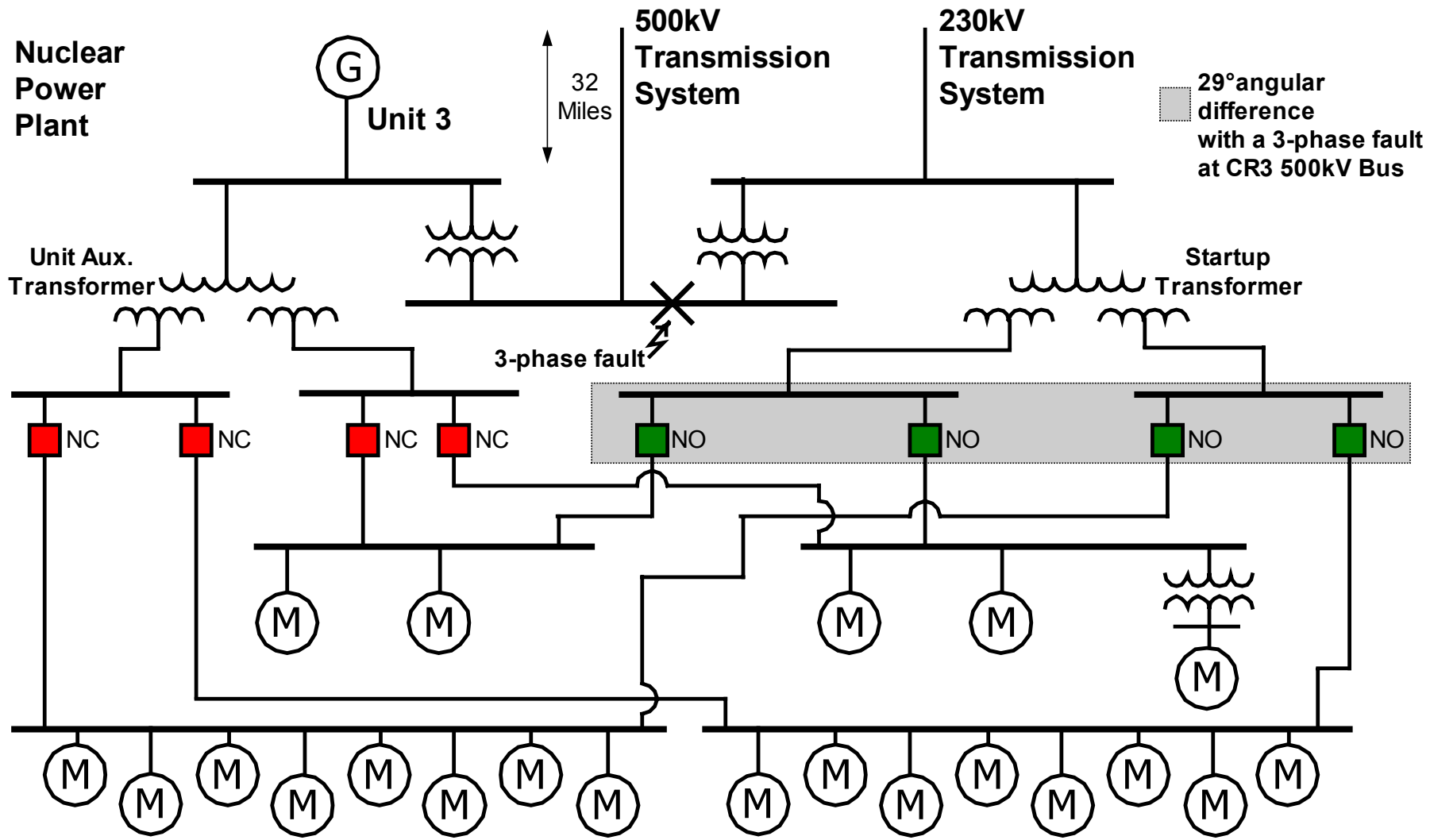

Transient Effects upon Disconnect of Motor Loads

- Essentially instantaneous phase shift upon disconnect of Motor.
 - Simulation based on 1000 Hp Induction Motor operating at full load supplied from 4160 Vac bus.
 - Instantaneous phase shift of 9 to 10 degrees in the slow direction calculated upon disconnect.
 - Effect is additive to conditions occurring due to other causes.
 - Effect is followed by subsequent frequency decay, the speed of which is dependent on inertia and loading of motor.

- Same effect occurs upon disconnect subsequent to a bus fault.

Phase Angle and Motor Bus Voltage Characteristics

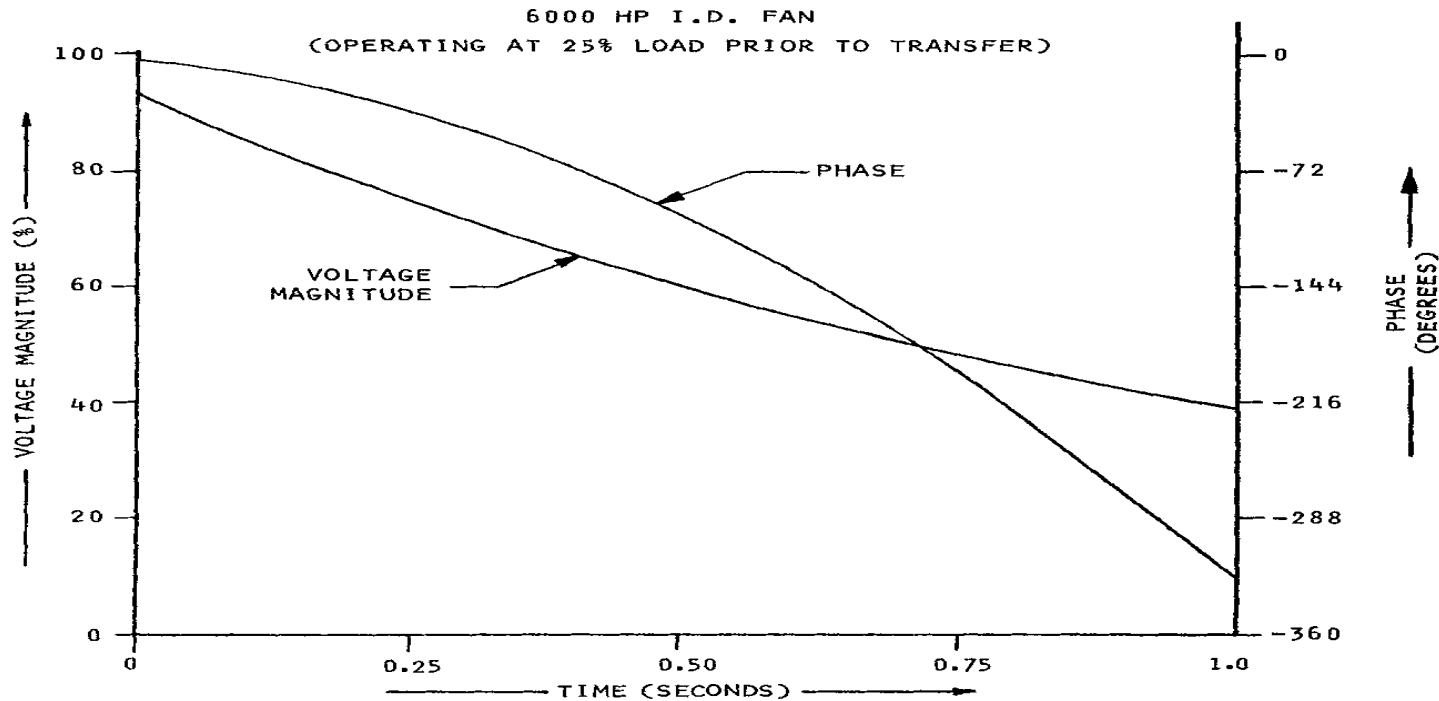

Phase angle rate of change (caused by deceleration of the motors during transfer) and the rate of voltage decay determined by the type of motors in use and the type of loads being driven.

Coast Down of Low Inertia Load on a Large Induction Motor

960 HP Boiler Circulating Pump
(Operating at Full Load)

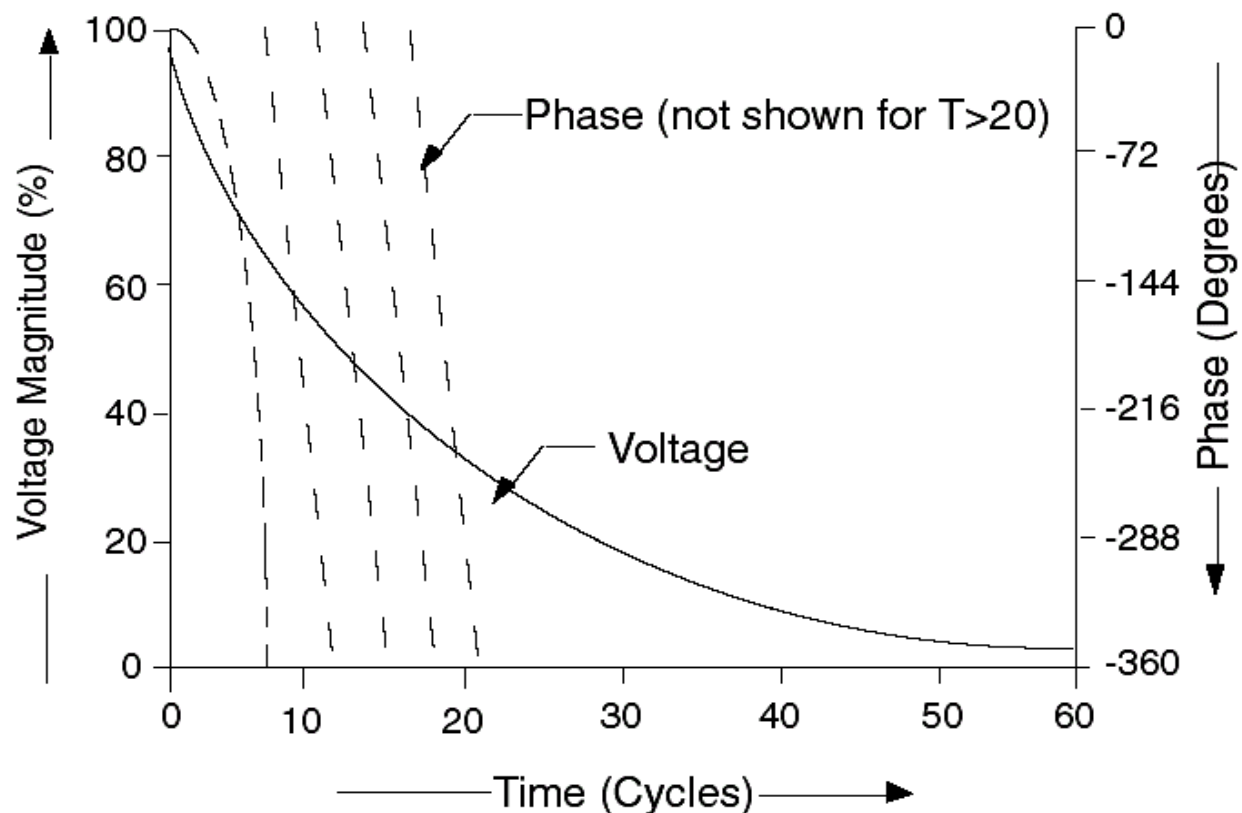

Motor & Load Characteristics: Effects on MBT

- **Motor Size**: The larger the motor, the longer the time the voltage will take to decay on an induction motor.
- **Loading**: The higher the load on the motors, the faster the motor bus frequency will decay.
- **Inertia**: The higher the inertia of the aggregate motor loads on the motor bus, the more slowly the motor bus frequency will decay during the disconnected coast down period. That has a direct impact on how fast the phase angle changes.
 - Low inertia loads will cause the phase angle to change quickly, as the frequency of motor bus decays quickly, and the slip frequency between the motor bus and the new source quickly increases.

Motor & Load Characteristics: Effects on MBT

■ Mix of Synchronous and Induction Motors:

- Voltage will tend to decay much more rapidly on a motor bus with all induction motors
- On a motor bus with a mix of synchronous and induction motors, the synchronous motors will attempt to hold up the voltage during the transfer interval

Motor Bus Transfer Classification (IEEE)

- Closed Transition
 - Hot Parallel Transfer
- Open Transition - Methods
 - Fast Transfer
 - In-Phase Transfer
 - Residual Voltage Transfer
 - Fixed Time Transfer
- Open Transition - Modes
 - Sequential
 - Simultaneous